

## 1. Introduction

The Smart-Encoder effectively eliminates multiple encoder part numbers by bringing intelligence and security to the design. In seconds, a four-digit LED display with two push-buttons enables the Smart-Encoder to change its resolution (counts per turn) as well as set a password to protect unauthorized changes. Our intuitive design eliminates the need for PCs or external devices for programming.

Additional features of the Smart-Encoder including reverse voltage protection of the inputs in addition to, short-circuit protection of the outputs. It is designed to operate within a wide range of industrial applications under harsh environmental conditions such as mechanical shock, vibrations, extreme temperature and humidity changes, oil mists, coolants and solvents. Nema 4 and 4x rated, submersible and explosion proof, Class 1, Div 1 models are also offered to suit a virtually limitless number of applications. The Smart-Encoder is available with the most common connectors found on the market making it a universal drop-in replacement for many brands of encoders.

## 2. Specifications

### ELECTRICAL

#### INPUT

- Voltage: 10-30 VDC (for 30V/V model)
- Voltage: 5 VDC (for 5V/V model)
- Current: 100 mA @ 24VDC exclusive of load
- High Voltage: Min. 2.4 VDC TTL Compatible
- Low Voltage: Max. 0.4 VDC TTL Compatible

#### PROTECTION

- Reverse Voltage Protected Inputs
- Short Circuit Protected Outputs

#### POWER-ON SETTling TIME

- Upon power-up the outputs are tri-stated for up to 100mSec.

### ENVIRONMENTAL

#### OUTPUT FORMAT:

- Incremental
- 2 models: Programmable up to 1024 or 4096 Pulses Per Rev.

#### OUTPUT DRIVERS

- Line driver device: ET7272
- Voltage: 30V/V = 10-30VDC ( $V_{in} = V_{out}$ )  
30V/5= 5VDC, 5V/5V = 4.5/5Vin
- Max Output Current: 40mA
- High Voltage: Vcc 0.5V@ 20mA source current
- Low Voltage: 0.5V @ 20mA sink current

- Line driver device: ET7273 for open collector outputs

Housing	Size 40 ( 4.0" dia.)	Size 40 explosion proof	Size 25 (2.5" dia.)
Max. Starting Torque @ 25 °C (oz. in.)	8(576.1)	8(576.1)	5(360.04)
Moment of Inertia (oz*in <sup>2</sup> )	6.4 x 10 <sup>-4</sup>	6.4 x 10 <sup>-4</sup>	4.0 x 10 <sup>-4</sup>
Max. Slew Speed (RPM)	5000	5000	5000
Shaft Size	5/8"	5/8"	3/8"
Max. Shaft Loading Axial and Radial:	120 lb.	120 lb.	80 lb.
Bearing Life at Max. Mfr. Spec.	2 x 10 <sup>9</sup>	2 x 10 <sup>9</sup>	2 x 10 <sup>9</sup>
Shock	150g for 11ms		100g for 11ms
Vibration	20g to 2000Hz		20g to 2000Hz
Enclosure	NEMA 4/IP 66	NEMA 4x (Div1 , Class 1, Group B,C,D)	
Operating Temperature	-20°C to 85° C		
Storage Temperature	-40°C to 85°C		

## 3. Wiring

1. The shielded interconnecting cable should be routed in its own conduit and kept separate from other high voltages/high inductance wiring. The shield drain wire should be connected to earth ground at both ends of cable.

2. Use appropriate mating connector (5 pin, 7 pin, 8 pin or 10 pin)

### CAUTION:

- Upon power-up the outputs are tri-stated for up to 100mSec.
- Check the cable wiring before applying power to the Smart-Encoder.

10- Pin M18 DL Connector Pin Out

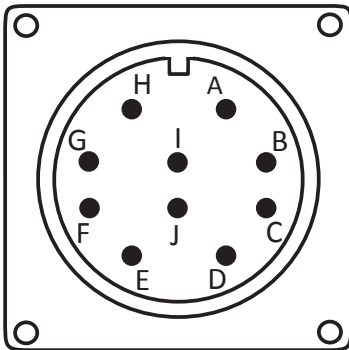

10- Pin M12 MS Connector Pin Out

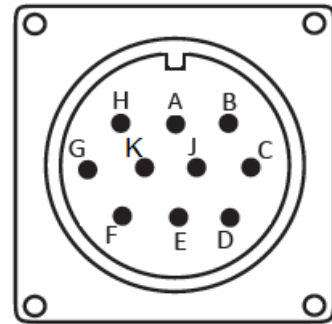

Table 1: 10DL (10 Pin Differential)

Connector Pin	Function	Cable Color Code
A	Signal A	Red
B	Signal B	Yellow
C	Signal Z	Green
D	Power Source (+V)	White
E	Not Connected	-
F	Com (-V)	White/Black
G	Case Ground	-
H	Signal A'	Red/Black
I	Signal B'	Yellow/Black
J	Signal Z'	Green/Black

Table 2: 10DM (10 Pin Differential)

Connector Pin	Function	Cable Color Code
A	Signal A	Red
B	Signal B	Yellow
C	Signal Z	Green
D	Power Source (+V)	White
E	Not Connected	-
F	Com (-V)	White/Black
G	Case Ground	-
H	Signal A	Red/Black
K	Signal B	Yellow/Black
J	Signal Z	Green/Black

Table 2: 05SL (5 Pin Single Ended )

Pin	Function	Wire Color
1	Power Source (+V)	White
2	Signal B	Yellow
3	Com (-V)	White/Black
4	Signal A	Red
5	Signal Z	Green

5- Pin M12 Connector Pin Out

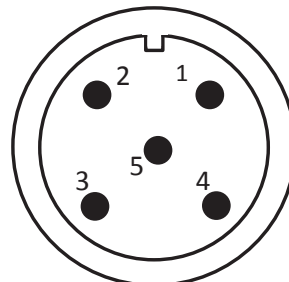

## 8- Pin M12 Connector Pin Out

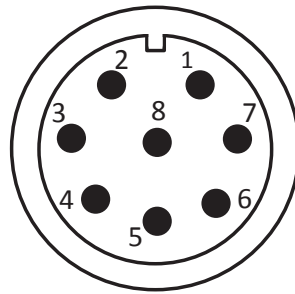

**Table 3: 08DL (8 Pin Differential)**

Pin	Function	Wire Color
1	Signal A	Red
2	Power Source (+V)	White
3	Signal A'	Red/Black
4	Signal B	Yellow
5	Signal B'	Yellow/Black
6	Signal Z	Green
7	Com (-V)	White/Black
8	Signal Z'	Green/Black

**Table 4: 08SL (8 Pin Single Ended)**

Pin	Function	Wire Color
1	Signal A	Red
2	Power Source (+V)	White
3	Not Connected	-
4	Signal B	Yellow
5	Not Connected	-
6	Signal Z	Green
7	Com (-V)	White/Black
8	Not Connected	-

## 7- Pin M16 Connector Pin Out

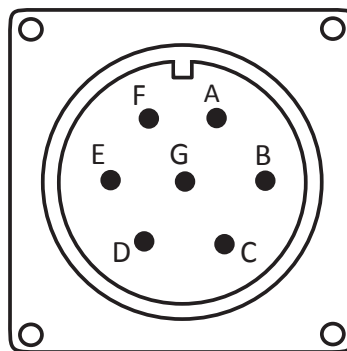

**Table 5: 07DL (7 Pin Differential)**

Pin	Function	Wire Color
A	Signal A	Red
B	Signal B	Yellow
C	Signal A'	Red/Black
D	Power Source (+V)	White
E	Signal B'	Yellow/Black
F	Com (-V)	White/Black
G	Case Ground	-

**Table 6: 07SL (7 pin Single Ended)**

Pin	Function	Wire Color
A	Signal A	Red
B	Signal B	Yellow
C	Signal Z	Green
D	Power Source (+V)	White
E	Not connected	-
F	Com (-V)	White/Black
G	Case Ground	-

## 4. Mounting

### Types of Mounting

#### 1. Servo-Mount

The Smart-Encoder can be either mounted with traditional servo-clamps or through the four 6-32 mounting holes on the face of the resolver.

*Zero Reference ( $\pm 5^\circ$ ):* The position at which the flat on the shaft lines up with the screw in the case and the two mounting holes on the Smart-Encoder's face plate.

#### 2. Flange-Mount

The Smart-Encoder can be mounted using the four mounting holes on the square face plate. *Zero Reference ( $\pm 5^\circ$ ):* The position at which the flat on the shaft lines up with the screw on the housing along with the mounting hole on the Smart-Encoder's face plate.

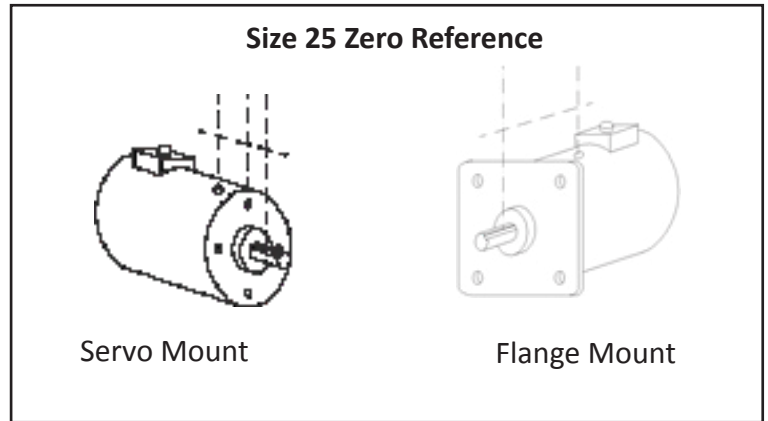

### Mounting Dimensions

#### 1. Size 25 Optical (Flange Mount)

Units: [mm]  
inches

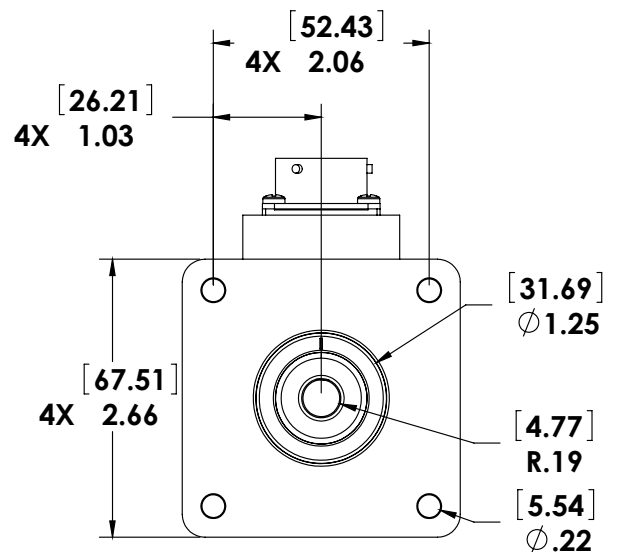
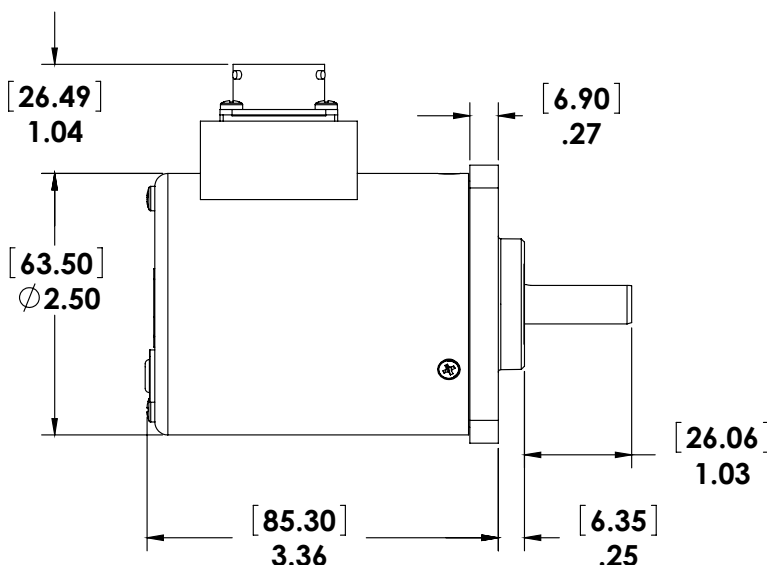
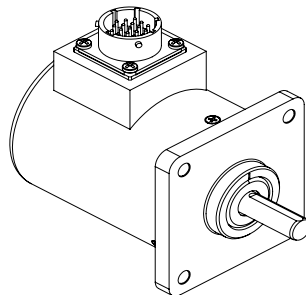

# Smart-Encoder™ : Optical Incremental



## 2. Size 25 Optical (Servo Mount)

Units: [mm]  
inches

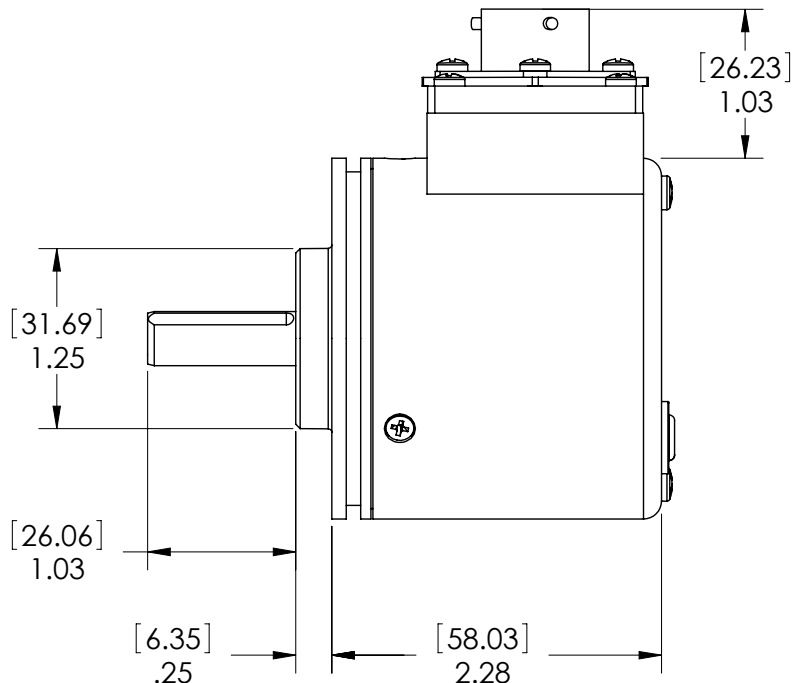
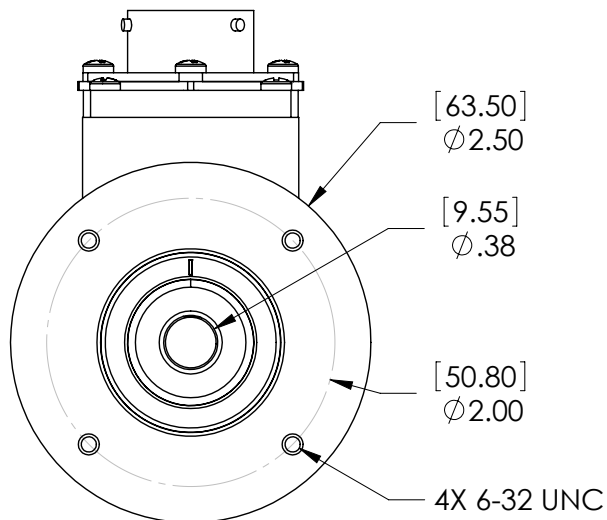

## 5. How to Order

**A****XX** – **PI** – **XXXX**-**X** – **XXXX** – **S** – **XXXX** – **XX**  
**1**     **2**     **3**     **4**     **5**     **6**     **7**     **8**

**1. Size**

- 25** 2.5" Diameter
- 40** 4.0" Diameter

**2. Output Format**

- PI** Optical Incremental

**3. PPR**

- 1024 model**
- 4096 model**

**4. Mounting**

- F** Flange Mount
- S** Servo Mount

**5. Input Power/ Output Driver (ET7272)**

- 30V/V** 10-30Vin , Vin=Vout
- 30V/5** 10-30Vin , Vout =5V (TTL compatible)
- 30V/OC** 10-30Vin, Output Collector (ET7273)
- 5V/V** 4.75 - 5.25Vin and Vout

**6. Output Connector Location**

- S** Side mount

**7. Output Connector Type**

- 05SL** 5pin Single line Incremental
- 07SL** 7pin Single line Incremental
- 07DL** 7pin Differential Incremental
- 08SL** 8pin Single line Incremental
- 08DL** 8pin Differential Incremental
- 10DL** 10pin Differential M18 Incremental
- 10DM** 10pin Differential M12 Incremental

**8. Construction/ Housing**

- AL** Aluminum
- EX** Explosion Proof (Size 40 Only)
- SS** Stainless Steel, Water Submersible

**Product Number Example: A25 – PI – 4096-F – 30V/5 – S – 10DL – AL**

2.5" Diameter Encoder, Optical, Incremental Type output, Up to 4096 PPR, 5V Output Voltage, 10 pin Differential Side Connector, Aluminum Housing.

### Cables

- CBD-10DL-Mxxx** Communication Cable with a 10-pin connector attached, M18
- CBD-10DM-Mxxx** Communication Cable with a 10-pin connector, M12
- CBD-05SL-Mxxx** Communication Cable with a 5-pin connector attached (Single-line)
- CBD-07SL-Mxxx** Communication Cable with a 7-pin connector attached (Single-line)
- CBD-07DL-Mxxx** Communication Cable with a 7-pin connector attached (Differential)
- CBD-08SL-Mxxx** Communication Cable with an 8-pin connector attached (Single-line)
- CBD-08DL-Mxxx** Communication Cable with an 8-pin connector attached (Differential)

## 6. Programming

The Smart-Encoder has a 7-segment LED Display (shown below) which can be used for programming the user parameters.

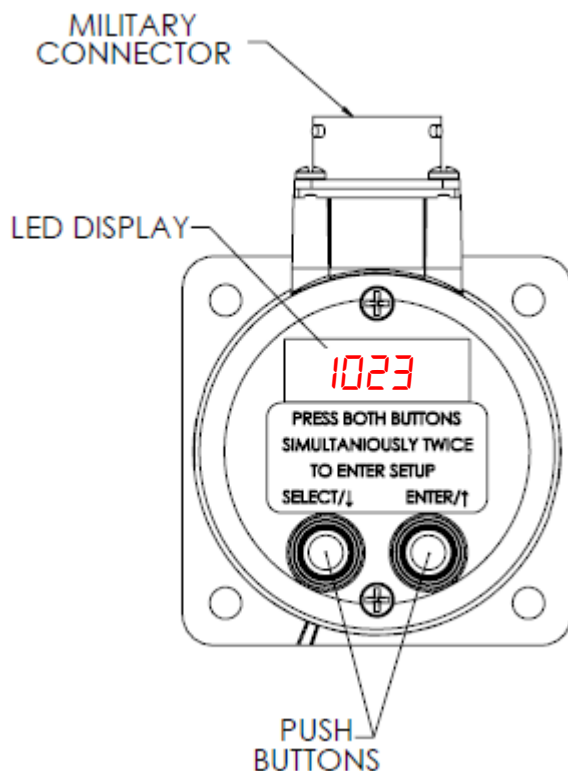

The Smart-Encoder has two (2) modes of operation **Run Mode** and **Programming Mode**.

### 1. Run Mode:

When in Run Mode the encoder will display the position or RPM (Revolutions Per Minute). To differentiate between the two parameters, the Resolver includes a decimal point following the right-most digit while displaying the RPM.

### Left Pushbutton:

Pressing the Left Push button in run mode toggles between the position and RPM display.

### Right Pushbutton:

Pressing the Right Push button in the run mode provides the user with a quick overview of the Encoder's Resolution setting and the Firmware Version. After automatically scrolling through the values, the display returns to the Run Mode.

RUN MODE	EXAMPLE
Position	0344
RPM	0311.

Parameter Overview	
Firmware Version	uEr
Resolution	rE5

## 2. Programming Mode

- To enter the programming mode press both of the push buttons simultaneously twice.
- Use the left push button to navigate through the parameters to be set.
- Use the right push button to select the parameter to be programmed.
- Use left push button to decrement and the right to increment values.
- Press both of the push buttons simultaneously to save the changes, program the flash and return to “Programming Mode” (all done in one step).
- After 10 sec. of inactivity in Programming Mode, the Encoder will discard the changes and go back to Run mode.

The following parameters may be programmed on the Smart- Encoder:

Main Menu		
1	Resolution	rES
2	Password	PASS

\* If a password has been previously set, upon entering the programming mode the user is immediately prompted to enter the password. The LED display shows **PASS** momentarily and then **0000**. The left push button decreases the value while the right push button increases it. Once the desired value is set press both pushbuttons simultaneously to enter the password.

- If an incorrect password is entered, the display prompts for the password once more.
- If an incorrect password is entered again, the display shows **bAd** briefly and then returns to Run Mode.

### Resolution

In **rES** mode, the encoder displays the current resolution (counts per turn). The programmable resolution range is 2- 1024 Pulses Per Revolution. To decrease the resolution use the left push button and to increase use the right push button. Pressing both push buttons simultaneously saves the current resolution and brings the Smart-Encoder back to the Programming menu.

### Password

In **PASS** mode, the encoder displays **0n** to indicate a password on or **oFF** to indicate password feature disabled.

Pressing any one of the push buttons toggles between password “on” and “off”. To disable password feature choose **oFF** and press both push buttons simultaneously. The encoder will then return to Run Mode. To enable password protection choose **0n**. The encoder then shows the current password stored in memory. The right push button increases the value while left push button decreases it. When the desired value has been selected, pressing both the push buttons simultaneously saves the new password, and returns the Smart-Encoder to Run Mode.

\*For instructions on resetting the password please consult the factory .



## 3. Programming Example

This example will illustrate how to program the encoder with the following parameters: a resolution of 1024 pulses per revolution and a password set to "1111".

- a. Wire the encoder according to the wiring instructions on page 2 and supply the appropriate power.
- b. The encoder is now in Run Mode. Press the left push button to see the RPM while rotating the shaft of the encoder.
- c. Press both push buttons twice simultaneously to enter Programming Mode. The LCD display will now show *rES*.
- d. Press the right push button to enter resolution set mode and use the left and right push button to increment and decrement (respectively) the counts per turn. Once you reach *1024* press both push button simultaneously to save the setting.
- e. The encoder should now display the next programming option, the password: *PASS*. Press the right push button to enter password set mode.
- f. Use the left or right push buttons to toggle the password to *0n*. Now press both of the push buttons simultaneously to save the setting.
- g. The screen will now display *0000*. Using the left push button increment the password to *1111*. Press both push buttons to save the password.
- h. The encoder is now back in Run Mode.

This completes the programming example. You may check the resolution by pressing the right push button while in run mode.

To enter programming mode use password *1111*.

You may change your password in the same manner that it was set in this example.

\*For instructions on resetting the password please consult the factory .

## 4. Programming Flowchart

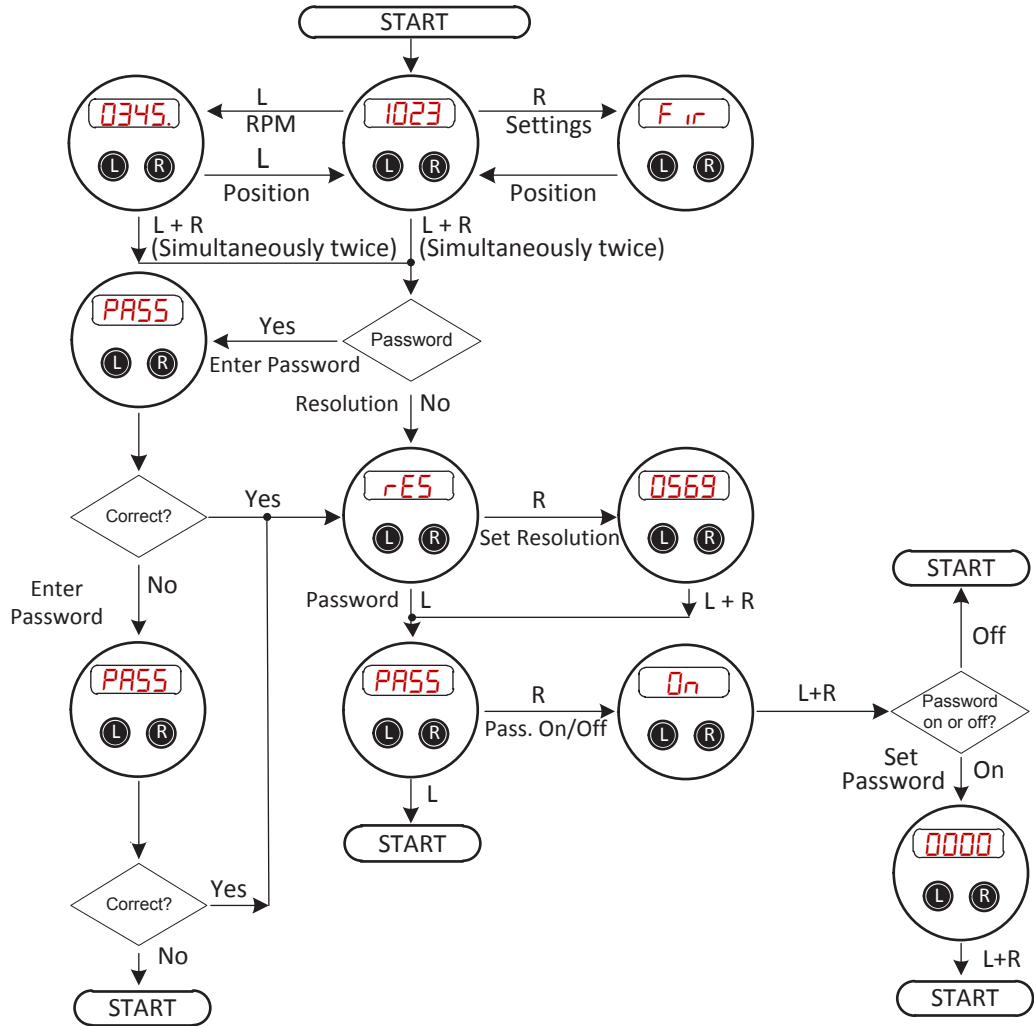

### NOTES

- Press "L + R" Simultaneously twice to enter programming mode.
- Use "L" ( left push button) to decrease value, advance to next programming mode, or toggle settings.
- Use "R" ( right push button) to decrease value, select the current setting to be programmed, or toggle settings.
- While setting a parameter press "**L+R**" **once to save changes** and advance to the next mode.
- While navigating, **press "L+R" once to return to Run Mode** (Position or RPM Display)
- While in programming mode, after 10 sec. of inactivity the encoder will return to Run Mode.